

# Brånemark System® Mk III

## Instructions for use



### Important: Please read.

#### Disclaimer of liability:

This product is part of an overall concept and may only be used in conjunction with the associated original products according to the instructions and recommendation of Nobel Biocare. Non-recommended use of products made by third parties in conjunction with Nobel Biocare products will void any warranty or other obligation, express or implied, of Nobel Biocare. The user of Nobel Biocare products has the duty to determine whether or not any product is suitable for the particular patient and circumstances. Nobel Biocare disclaims any liability, express or implied, and shall have no responsibility for any direct, indirect, punitive or other damages, arising out of or in connection with any errors in professional judgment or practice in the use of Nobel Biocare products. The user is also obliged to study the latest developments in regard to this Nobel Biocare product and its applications regularly. In cases of doubt, the user has to contact Nobel Biocare. Since the utilization of this product is under the control of the user, they are his/her responsibility. Nobel Biocare does not assume any liability whatsoever for damage arising thereof. Please note that some products detailed in this Instruction for Use may not be regulatory cleared, released or licensed for sale in all markets.

#### Description:

##### Implant:

Brånemark System® Mk III dental implants with external hexagon connection are made from biocompatible commercially pure grade 4 titanium with machined surface. The Cover Screw is made of titanium alloy Ti-6Al-4V.

The Brånemark System® Mk III is a parallel walled implant recommended for all bone qualities. The implants have a machined collar of 0.8mm for NP 3.3, RP 3.75 and RP 4.0mm, and a 0.2mm collar for WP 5.0mm. Cover screw is co-packed with implant.

##### Tooling:

Nobel Biocare Twist Drills, Twist Step Drills, Counterbores and Screw Taps are made of stainless steel with DLC (Diamond Like Carbon) coating and should be used in conjunction with Brånemark System® Mk III implants.

#### Intended use:

Brånemark System® Mk III implants are intended to be used in the upper or lower jaw bone (osseointegration) and used for anchoring or supporting tooth replacements to restore chewing function.

#### Indications:

Brånemark System® Mk III implant restorations range from single tooth to fixed-removable full dental arch overdenture applications to restore chewing function. This can be achieved by a 2-stage or 1-stage surgical technique in combination with immediate, early or delayed loading protocols, recognizing sufficient primary stability and appropriate occlusal loading for the selected technique. Implants allow also for bi-cortical anchorage in cases of reduced bone density to obtain high initial stability.

#### Contraindications:

It is contraindicated placing Brånemark System® Mk III implants in patients:

- who are medically unfit for an oral surgical procedure.
- with inadequate bone volume unless an augmentation procedure can be considered.
- in whom adequate sizes, numbers or desirable positions of implants are not reachable to achieve safe support of functional or eventually parafunctional loads.
- allergic or hypersensitive to commercially pure titanium grade 4 or titanium alloy Ti-6Al-4V (titanium, aluminum, vanadium).

#### Warnings:

Failure to recognize actual lengths of drills relative to radiographic measurements can result in permanent injury to nerves or other vital structures. Drilling beyond the depth intended from lower jaw surgery may potentially result in permanent numbness to the lower lip and chin or lead to a hemorrhage in the floor of the mouth.

Besides the mandatory precautions for any surgery such as asepsis, during drilling in the jaw bone, one must avoid damage the nerves and vessels by referring to anatomical knowledge and preoperative radiographs.

#### Cautions:

##### General:

One hundred percent implant success cannot be guaranteed. Especially, non-observance of the indicated limitations of use and working steps may result in failure.

Treatment by means of implants may lead to loss of bone, biologic or mechanical failures including fatigue fracture of implants.

Close cooperation between surgeon, restorative dentist and dental laboratory technician is essential for a successful implant treatment.

It is strongly recommended that Brånemark System® Mk III implants are used only with Nobel Biocare surgical instruments and prosthetic components, as combining components that are not dimensioned for correct mating can lead to mechanical and/or instrumental failure, damage to tissue or unsatisfactory esthetic results.

It is strongly recommended that clinicians, new as well as experienced implant users, always go through special training before undertaking a new treatment method. Nobel Biocare offers a wide range of courses for various levels of knowledge and experience.

For more info please visit [www.nobelbiocare.com](http://www.nobelbiocare.com).

Working the first time with a colleague, experienced with the new device/treatment method, avoids eventual complications. Nobel Biocare has a global network of mentors available for this purpose.

##### Before surgery:

Careful clinical and radiological examination of the patient has to be performed prior to surgery to determine the psychological and physical status of the patient.

Special attention has to be given to patients who have local or systemic factors that could interfere with the healing process of either bone or soft tissue or the osseointegration process (e.g., cigarette smoking, poor oral hygiene, uncontrolled diabetes, oro-facial radiotherapy, steroid therapy, infections in the neighboring bone).

Special caution is advised in patients who receive bisphosphonate therapy.

In general, implant placement and prosthetic design must accommodate individual patient conditions. In case of bruxism or unfavorable jaw relationships reappraisal of the treatment option may be considered.

With respect to pediatric patients, routine treatment is not recommended until the end of the jaw bone growth phase has been properly documented.

Pre-operative hard tissue or soft tissue deficits may yield a compromised esthetic result or unfavourable implant angulation.

#### At surgery:

Particular caution should be used when placing narrow platform implants in the posterior region due to risk of prosthetic overload.

All instruments and tooling used during procedure must be maintained in good condition and care must be taken that instrumentation does not damage implants or other components.

Because of the small size of components, care must be taken that they are not swallowed or aspirated by the patient.

Brånemark System® Mk III implants may be tilted up to 45° relative to the occlusal plane. When used with angulations between 30° and 45°, the following applies: The tilted implant must be splinted; a minimum of 4 implants must be used when supporting a fixed prosthesis in a fully edentulous arch.

After the implant installation, the surgeon's evaluation of bone quality and initial stability will determine when implants may be loaded. Lack of adequate quantity and/or quality of remaining bone, infection and generalized diseases may be potential causes for failure of osseointegration both immediately after surgery, or after osseointegration is initially achieved.

#### After surgery:

To secure the long term treatment outcome it is advised to provide comprehensive regular patient follow up after implant treatment and to inform about appropriate oral hygiene.

#### Surgical procedure:

During drilling procedures bone quality should be considered (please see table A: recommended drill sequences are based on bone quality to ensure optimal primary stability when applying immediate function).

The recommended drill sequence is based on bone quality. Drill data are stated in mm and the drills within brackets denote widening of cortex only.

Counterbores and Screw Taps are available if deemed necessary.

### A

Platform	Implant	Drill Sequence (according to bone quality)		
		Soft bone	Medium bone	Dense bone
NP	3.3	Ø 2.0 (Ø 2.4/2.8)	Ø 2.0 Ø 2.4/2.8	Ø 2.0 Ø 2.4/2.8
RP	3.75	Ø 2.0 (Ø 2.4/2.8)	Ø 2.0 Ø 2.4/2.8 Ø 3.0	Ø 2.0 Ø 2.4/2.8 Ø 3.2
RP	4.0	Ø 2.0 (Ø 2.4/2.8)	Ø 2.0 Ø 2.4/2.8 Ø 3.2	Ø 2.0 Ø 2.4/2.8 Ø 3.4
WP	5.0	Ø 2.0 Ø 2.4/2.8 (Ø 3.2/3.6)	Ø 2.0 Ø 2.4/2.8 Ø 3.2/3.6 (Ø 3.8/4.2)	Ø 2.0 Ø 2.4/2.8 Ø 3.2/3.6 Ø 3.8/4.2

Drilling must proceed at high speed (max. 2'000rpm/min for Twist Drills and Twist Step Drills) under constant and profuse irrigation by sterile saline at room temperature. In dense bone situation drill with continuous back and forth motion.

Depth measurement system: The parallel drills have a true depth measurement system. All drills and components are marked to prepare the site to the correct depth and obtain a secure and predictable position.

**Caution:** Twist Drills and Twist Step Drills extend up to 1 mm longer than the implant when seated. Allow for this additional length when drilling near vital anatomical structures (please see image B for drill reference lines).

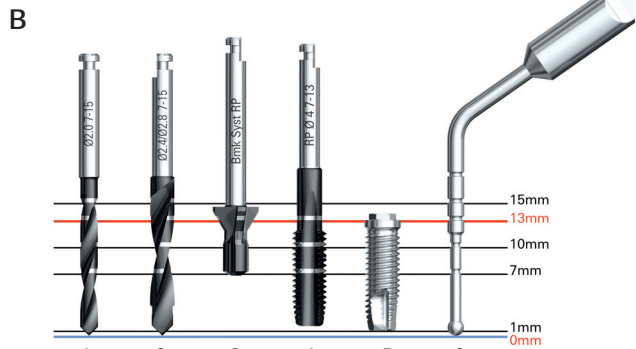

Drill reference lines for Twist Drill 7–15 mm (1), Twist Step Drill 7–15 mm (2), Counterbore (3), Screw Tap 7–13 mm (4), Brånemark System® Mk III implant 13 mm (5) and Depth Probe 7–18 mm (6).

Twist Drills and Twist Step Drills are available in three different lengths with depth markings for 7–10 mm, 7–15 mm and 10–18 mm implants.

Screw Taps are available with depth markings for NP 10–15 mm, RP and WP 7–13 mm and 7–18 mm implants.

**Note:** The marks on the Twist Drills and Twist Step Drills indicate actual millimeter lengths and correspond to the implant collar. Final vertical positioning depends on several clinical parameters, including esthetics, tissue thickness and available vertical space.

In situations where adjacent natural teeth interfere with the contra-angle head preventing the drill from reaching the desired depth, a drill extension shaft may be used.

1. Prepare implant site (C). When using a flapless approach add-on soft tissue height to drill depth.



2. Measure the final depth of implant site for applicable implant length using depth probe with same measurements as Twist Drills and Twist Step Drills.
3. Open the implant package and pick up the implant from inner casing with implant driver (please see D). The implants are ideally installed with low speed, max. 25 rpm/min using a Drill Device (D) or Manual Torque Wrench Surgical (E).

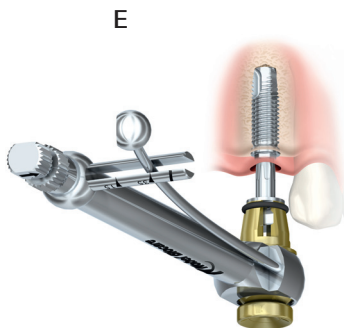
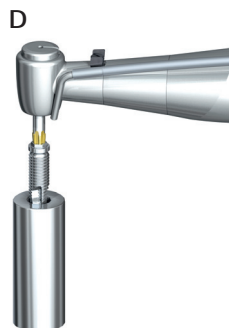

4. Place and tighten the implant using max. **45 Ncm** insertion torque.

**Caution:** Never exceed insertion torque of **45 Ncm** for the implants. Over tightening an implant may lead to damage of the implant, fracture or necrosis of the bone site. If a Surgical Driver is used to insert the implant, special care needs to be taken to avoid over tightening.

If the implant gets stuck during implant installation or **45 Ncm** of insertion torque is achieved before fully seated, rotate the implant counter clockwise using Drilling Device (reverse mode) or Manual Torque Wrench and remove implant from site. Replace the implant back into inner casing before proceeding further.

5. Dense bone protocol to be used when implant will not be fully seated.
  - a. In cases of a thick cortical layer or dense bone a Counterbore and/or a Screw Tap is recommended to be able to get the implant fully seated and to release pressure around the implant neck.
  - b. Select the Screw Tap matching the diameter of the implant.
  - c. Place the Screw Tap into prepared implant site using low speed 25 rpm/min and drill to appropriate depth. Switch the Drill Device with Handpiece or Manual Torque Wrench Surgical to reverse mode and remove the Screw Tap.

Continue with implant installation until desired position is achieved using max. **45 Ncm** installation torque.

6. For Immediate Function, the implant should be able to withstand a final torque of **35–45 Ncm**.
7. Depending on surgical protocol of choice, place a Cover Screw or Abutment and suture (F).

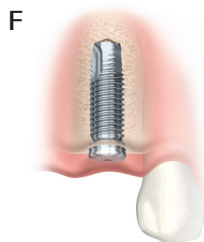

See table for implant specifications for Brånemark System® Mk III (G).

## G

### Brånemark System® Mk III machined

Platform	Platform diameter	Implant diameter	Lengths
	Ø 3.5 mm	Ø 3.3 mm	10 mm, 11.5 mm, 13 mm, 15 mm
	Ø 4.1 mm	Ø 3.75 mm	7 mm, 8.5 mm, 10 mm, 11.5 mm, 13 mm, 15 mm, 18 mm
	Ø 4.1 mm	Ø 4.0 mm	7 mm, 8.5 mm, 10 mm, 11.5 mm, 13 mm, 15 mm, 18 mm
	Ø 5.1 mm	Ø 5.0 mm	7 mm, 8.5 mm, 10 mm, 11.5 mm, 13 mm, 15 mm

For additional information on surgical procedures please consult the Brånemark System® Mk III TiUnite® “Procedures & products” treatment guidelines available at [www.nobelbiocare.com](http://www.nobelbiocare.com) or request latest printed version from a Nobel Biocare representative.

## Materials:

Brånemark System® Mk III machined: commercially pure titanium grade 4.  
Cover Screw: titanium alloy Ti-6Al-4V (titanium, aluminum, vanadium).  
Twist Drills, Twist Step Drills, Counterbores and Screw Taps: stainless steel with DLC (Diamond Like Carbon) coating.

## Cleaning and sterilization:

Brånemark System® Mk III machined implants, Cover Screws, Twist Drills, Twist Step Drills, Counterbores and Screw Taps are delivered sterile and for single use only prior to the labeled expiration date.

**Warning:** Do not use device if the packaging has been damaged or previously opened.

**Caution:** Implants, Cover Screws, Twist Drills, Twist Step Drills, Counterbores and Screw Taps are single use products not intended to be reprocessed. Reprocessing could cause loss of mechanical, chemical and/or biological characteristics. Reuse could cause cross contamination.

## MR safety information:

Please note that the product has not been evaluated for safety and compatibility in the MR environment. The product has not been tested for heating or migration in the MR environment.

For additional information on Cleaning and Sterilization and Magnetic Resonance Imaging, please consult the “Cleaning & Sterilization Guidelines for Nobel Biocare Products including MRI Information” available at [www.nobelbiocare.com/sterilization](http://www.nobelbiocare.com/sterilization) or request latest printed version from a Nobel Biocare representative.

## Storage and handling:

The product must be stored in a dry place in the original packaging at room temperature and not exposed to direct sunlight. Incorrect storage may influence device characteristics leading to failure.

## Disposal:

Disposal of the device shall follow local regulations and environmental requirements, taking different contamination levels into account.

**Manufacturer:** Nobel Biocare AB, Box 5190, 402 26  
Västra Hamngatan 1, 411 17 Göteborg, Sweden.  
Phone: +46 31 81 88 00. Fax: +46 31 16 31 52. [www.nobelbiocare.com](http://www.nobelbiocare.com)

**Canada license exemption:** Please note that not all products may have been licensed in accordance with Canadian law.

## Prescription device: Rx only

**Caution:** Federal law restricts this device to sale by or on the order of a licensed physician or dentist.

0086

Rx Only

STERILE R

Sterile using irradiation

Consult instructions for use

Use-by date

Do not re-use

LOT

Batch code

Do not use if package is damaged

US All rights reserved.

Nobel Biocare, the Nobel Biocare logotype and all other trademarks used in this document are, if nothing else is stated or is evident from the context in a certain case, trademarks of Nobel Biocare. Product images in this folder are not necessarily to scale.