

# PureSet™ Tray

## Instructions for use

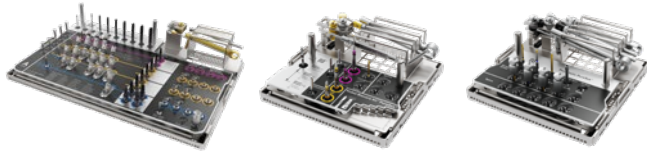

### **Important – Disclaimer of Liability:**

This product is part of an overall concept and may only be used in conjunction with the associated original products according to the instructions and recommendation of Nobel Biocare. Non-recommended use of products made by third parties in conjunction with Nobel Biocare products will void any warranty or other obligation, express or implied, of Nobel Biocare. The user of Nobel Biocare products has the duty to determine whether or not any product is suitable for the particular patient and circumstances. Nobel Biocare disclaims any liability, express or implied, and shall have no responsibility for any direct, indirect, punitive or other damages, arising out of or in connection with any errors in professional judgment or practice in the use of Nobel Biocare products. The user is also obliged to study the latest developments in regard to this Nobel Biocare product and its applications regularly. In cases of doubt, the user has to contact Nobel Biocare. Since the utilization of this product is under the control of the user, they are his/her responsibility. Nobel Biocare does not assume any liability whatsoever for damage arising thereof. Please note that some products detailed in this Instruction for Use may not be regulatory cleared, released or licensed for sale in all markets.

### **Description:**

PureSet™ Trays are reusable trays to be used in combination with Nobel Biocare surgical/prosthetic instruments and components. The PureSet™ Trays are used to store and organize the instruments and components during the surgical, restorative and reprocessing procedures.

The PureSet™ Tray consists of three parts: 1) a base with holders to accommodate the different surgical/prosthetic instruments and components, 2) a removable PureSet™ Plate (spare part) to indicate the surgical workflow (in case of the surgical tray) and the position of the instruments and components within the tray, and 3) a lid to securely contain the instruments during reprocessing.

There are different versions of the PureSet™ Tray available for the different Nobel Biocare surgical and prosthetic procedures. The instruments and components which are compatible with the various trays are specified in the respective wall charts. Please contact the local Nobel Biocare sales office for information regarding the wall charts.

### **Intended Use/Intended Purpose:**

Intended for use to organize, store, clean, and sterilize instrumentation or components used for dental implant surgical and prosthetic procedures.

### **Indications:**

Same as Intended Use/Intended Purpose.

### **Contraindications:**

None identified.

### **Cautions:**

#### **General:**

It is strongly recommended that Nobel Biocare PureSet™ Trays are used only with dedicated Nobel Biocare surgical instruments. The storage and organization of non-Nobel Biocare instruments in the PureSet™ Trays can lead to mechanical and/or instrumental failure.

When using a new device/treatment method for the first time, working with a colleague who is experienced with the new device/treatment method may help avoid possible complications. Nobel Biocare has a global network of mentors available for this purpose.

To avoid scratching the stainless-steel base, do not apply force, twist, or turn the drill around when evaluating the length of the drill's depth markings on the drill gauge.

### **Before Surgery:**

All components, instruments and tooling used during the clinical or laboratory procedure must be maintained in good condition and care must be taken that instrumentation does not damage implants or other components.

### **At Surgery:**

Care and maintenance of sterile instruments are crucial for a successful treatment. Sterilized instruments not only safeguard your patients and staff against infection but are also essential for the outcome of the total treatment.

### **Intended Users and Patient Groups:**

PureSet™ Trays are to be used by dental health care professionals.

### **Clinical Benefits and Undesirable Side Effects:**

#### **Clinical Benefits Associated with the PureSet™ Trays:**

PureSet™ Trays are used to clean and sterilize devices which are components of treatment with a dental implant system and/or dental crowns and bridges. As a clinical benefit of treatment, patients can expect to have their missing teeth replaced and/or crowns restored.

#### **Undesirable Side Effects Associated with the PureSet™ Trays:**

None known.

#### **Notice regarding serious incidents:**

For a patient/user/third party in the European Union and in countries with an identical regulatory regime (Regulation 2017/745/EU on Medical Devices); if, during the use of this device or as a result of its use, a serious incident has occurred, please report it to the manufacturer and to your national authority. The contact information for the manufacturer of this device to report a serious incident is as follows:

#### **Nobel Biocare AB**

<https://www.nobelbiocare.com/complaint-form>

### **Materials:**

- PureSet™ Tray: stainless steel (AISI 301/304/305/420), polyetheretherketone (PEEK), silicone.
- PureSet™ Plate: aluminum anodized with print.

Refer to the Nobel Biocare Instructions for Use (IFU) for the respective surgical/prosthetic instrument for information regarding the material composition of the instrument.

### **Sterility and Reusability Information:**

PureSet™ Trays (including the PureSet™ Plate and corresponding surgical/prosthetic instruments) are delivered non-sterile and are intended for reuse. Prior to first use and reuse clean and sterilize the products following the manual or automated procedure in the Cleaning and Sterilization Instructions.

**Warning:** Use of non-sterile devices may lead to infection of tissues or infectious diseases.

PureSet™ Trays, Plates, and any reusable surgical/prosthetic instruments shall be inspected prior to each use to ensure the integrity of the device is maintained. Any device with signs of corrosion and/or damage must be discarded and replaced.

The PureSet™ Plate is available as a spare part and should be replaced if the plate is discolored or if the legibility of the pictograms or the text is compromised.

**Note:** The PureSet™ Tray (excluding the PureSet™ Plate) has been validated to withstand at least 500 reprocessing cycles.

**Note:** The PureSet™ Plate has been validated to withstand at least 250 reprocessing cycles.

### **Cleaning and Sterilization Instructions:**

PureSet™ Trays (including the PureSet™ Plate) are delivered non-sterile by Nobel Biocare and are intended for reuse. Prior to each use, the PureSet™ Tray, Plate, and corresponding surgical/prosthetic instruments must be cleaned and sterilized by the user.

PureSet™ Trays, Plates, and instruments can be cleaned manually, or can be cleaned in an automatic washer. After cleaning, the fully-assembled PureSet™ is sealed in a metal sterilization container, sterilization pouch, or sterilization wrap and sterilized.

The following cleaning and sterilization processes have been validated according to international standards and guidelines as applicable:

- Manual/Automated Cleaning: AAMI TIR 12.
- Sterilization: AAMI ST79 and ISO 17665-1.

According to EN ISO 17664, it is the responsibility of the user/processor to ensure that the processing/reprocessing is performed using equipment, materials and personnel which are suitable to ensure the effectiveness of the processes. Any deviation from the following instructions should be validated by the user/processor to ensure the effectiveness of the process.

**Note:** The manufacturer's instructions for use for any detergent/cleaning solution and/or equipment and accessories used to clean and/or dry the device(s) must be strictly followed where applicable.

**Caution:** Do not deviate from the following reprocessing instructions.

### **Initial Treatment at Point of Use Prior to Reprocessing:**

1. During surgery, always return used reusable instruments back into their designated holders in the PureSet™ Tray (refer to the pictograms and color-coded workflow on the plate of the PureSet™ Tray). To avoid potential injury or exposure to contaminated instruments, it is advised to handle the instruments using a pair of tweezers.
2. Discard single-use instruments and worn reusable instruments immediately after use.
3. Remove excess soil and debris from reusable devices to be reprocessed within a maximum of 1 hour postoperatively using absorbent paper wipes.

**Caution:** Excess soil and debris should be removed from reusable devices within 1 hour of use to ensure the efficacy of the cleaning and sterilization procedures.

4. Rinse the devices with cold running tap water.

### **Containment and Transportation/Shipping to Reprocessing Area:**

1. After removal of excess soil and debris, store the PureSet™ Tray and instruments in a suitable container to avoid any contamination of personnel or the environment.
2. Transport the PureSet™ Tray and instruments to the reprocessing area as soon as practical. If transfer to the processing area is likely to be delayed, consider covering the PureSet™ Tray and instruments with a damp cloth or store it in a closed container to avoid drying of soil and/or debris.

**Caution:** Reusable devices should be reprocessed by initiating the prescribed automated or manual cleaning and drying procedures within 1 hour of use, to ensure the efficacy of the reprocessing.

3. If the devices are shipped to an outside facility for reprocessing, they must be contained in a transportation or shipping container which is suitable to protect the devices during transportation and to prevent contamination of personnel or the environment.

### **Disassembly of Multi-piece Instruments Prior to Cleaning:**

**Note:** The Manual Torque Wrench Surgical must be disassembled prior to cleaning by removing the adapter and the rod from the wrench body as shown in Figure A.

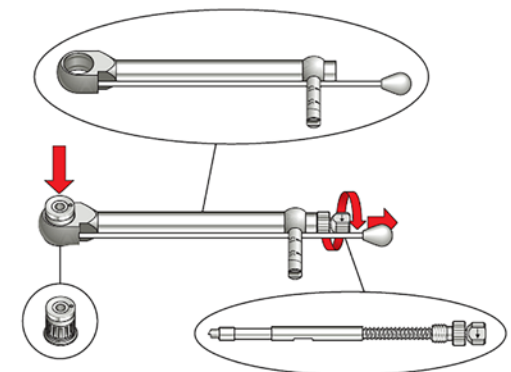
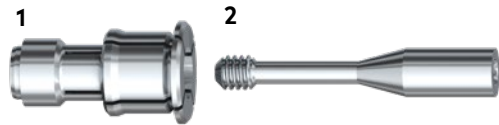

Figure A: Disassembly of the Manual Torque Wrench Surgical

**Note:** Implant Mounts must be disassembled prior to cleaning as follows:

Unscrew the Implant Mount Screw (2) from the Implant Mount Body (1), see **Figure B**.



**Figure B: Disassembly of the Implant Mount**

**Note:** Template abutments must be disassembled prior to cleaning as follows:

Unscrew the Template Abutment Screw (2) from the Template Abutment Body (1), see **Figure C**.

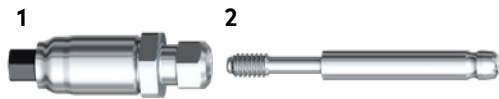

**Figure C: Disassembly of the Guided Template Abutment**

### Automated Cleaning and Drying (Including Pre-cleaning):

#### Pre-cleaning:

1. Remove all instruments from the PureSet™ Tray.
2. Remove the plate from the PureSet™ Tray.
3. Disassemble the multi-piece instruments as described above, where applicable.
4. Thoroughly rinse all instruments, including any lumina and/or difficult-to-reach areas with lukewarm tap water using a water pistol.
5. Place all instruments back into the designated holders in the PureSet™ Tray. Use the PureSet™ Plate as a reference to ensure the instruments are placed in the correct position. Keep the multi-piece instruments disassembled.
6. Place the PureSet™ Tray with instruments in an ultrasonic bath (e.g. Bandelin Sonorex 35 kHz 300 W) containing 0.5% solution of mildly alkaline detergent (e.g. Neodisher Mediclean) and treat for minimum of 10 minutes at minimum 40°C (104°F).

**Caution:** Do not place the PureSet™ Plate into the ultrasonic bath as this can damage the plate and impact the legibility of the text and pictograms.

#### Automated Cleaning and Drying:

The following washers were used in the Nobel Biocare validations: Steelco DS 500 and Miele G7836 CD.

1. Place the PureSet™ Tray containing the instruments and the plate into the washer separately. Ensure the PureSet™ Tray and plate are oriented in a vertical position.
- Caution:** Remove the PureSet™ Plate from the PureSet™ Tray prior to automatic cleaning to ensure the tray and instruments are adequately cleaned.
2. Perform automatic cleaning. The following parameters were used in the Nobel Biocare validation:
    - Minimum 2 minutes pre-washing with cold tap water at minimum 14°C (57°F).
    - Minimum 5 minutes washing with tap water with a 0.5% solution of mildly alkaline detergent (e.g. Neodisher Mediclean) at 55°C (131°F).
    - Minimum 3 minutes rinsing with cold demineralized water at minimum 18°C (64°F).

**Caution:** The use of a cleaning solution with acidic pH (pH < 7) could potentially damage the PureSet™ Plate.

3. Dry the PureSet™ Tray containing the instruments and the PureSet™ Plate at minimum 70°C (158°F) for a minimum of 10 min.

#### Manual Cleaning and Drying:

##### PureSet™ Tray and Plate:

1. Remove all the instruments from the PureSet™ Tray.
2. Remove the plate from the PureSet™ Tray.
3. Scrub the PureSet™ Tray under running tap water with a soft bristled nylon brush for a minimum of 3 minutes until all visible soil is removed.
4. Immerse a soft bristled nylon brush in a 0.5% solution of mildly alkaline detergent (e.g. Neodisher Mediclean) at minimum 40°C (104°F). Scrub the PureSet™ Plate with the soft bristled nylon brush for a minimum of 1 minute until all visible soil is removed. Ensure the entire surface of the plate is thoroughly scrubbed.

**Caution:** The use of a cleaning solution with acidic pH (pH < 7) could potentially damage the PureSet™ Plate.

5. Thoroughly rinse the PureSet™ Plate for a minimum of 1 minute under running tap water to remove all detergent.
6. Flush the grommets (instrument holders) with tap water using a water pistol for a minimum of 30 seconds.

7. Place the PureSet™ Tray (without the plate) into an ultrasonic bath (e.g. frequency 37 kHz effective ultrasonic power 400 W) for a minimum of 10 minutes with a 0.6% solution of mildly alkaline detergent (e.g. Neodisher Mediclean) at minimum 40°C (104°F).
8. Rinse the PureSet™ Tray for a minimum of 1 minute under cold running tap water to remove all cleaning solution.
9. Dry the PureSet™ Tray and the plate with suitable equipment (compressed air).

#### PureSet™ Instrumentation:

1. Disassemble the multi-piece instruments prior to cleaning as described above.
2. Immerse device for a minimum of 5 minutes in a sterile 0.9% NaCl solution.
3. Scrub the outer surfaces of the device with soft-bristled nylon brush for a minimum of 30 seconds until all visible soil is removed.
4. Flush the inner surfaces, lumina and cavities (where applicable) with 20 ml lukewarm enzymatic cleaning solution (e.g. Cidezyme ASP; Neodisher Medizym; maximum 45°C (113°F)) using an irrigation needle connected to a 20 ml syringe.
5. Brush the inner surfaces, lumina and cavities (where applicable) with appropriately sized bottle brush (e.g. 1.2 mm/2.0 mm/5.0 mm diameter) for a minimum of 30 seconds until all visible soil is removed.
6. Thoroughly rinse the outer surfaces and lumina of the device with cold running tap water for a minimum of 30 seconds to remove all cleaning solution.
7. Immerse the device in an ultrasonic bath (e.g. Bandelin frequency 35 kHz effective ultrasonic power 300 W) containing 0.5% lukewarm enzymatic cleaning agent (e.g. Cidezyme ASP; Neodisher Medizym) and treat for a minimum of 5 minutes at minimum 40°C (104°F)/maximum 45°C (113°F).
8. Flush the inner surfaces, lumina and cavities (where applicable) with 20 ml lukewarm tap water using an irrigation needle connected to a 20 ml syringe.
9. Flush the inner surfaces, lumina and cavities of Manual Torque Wrenches for a minimum of 15 seconds using a water jet pistol.
10. Thoroughly rinse the outer surfaces of the devices with purified or sterile water for a minimum of 30 seconds to remove all cleaning agent.
11. Dry with compressed air or clean and lint-free single use wipes.

#### Reassembly of the PureSet™ Tray, Plate, and Instrumentation:

Reassemble the PureSet™ Tray and plate, and replace the instruments (including multi-piece instruments) in their designated holders in the PureSet™ Tray (refer to the pictograms and color-coded workflow on the plate of the PureSet™ Tray). To avoid potential injury, it is advised to handle the instruments using a pair of tweezers.

**Caution:** Ensure that the plate is properly seated on the PureSet™ Tray to prevent damage to the plate or to instruments during subsequent handling.

**Caution:** Keep dissimilar metals separated to prevent corrosion during sterilization. Refer to the Materials section in the Nobel Biocare IFU for the respective surgical/prosthetic tooling for information regarding the metals contained in the device.

#### Visual Inspection:

After cleaning, drying, and reassembly of the PureSet™ Tray, plate, and instrumentation, inspect all components to confirm the functional integrity, to confirm the legibility of any text (where applicable) and to ensure there is no residual soil, corrosion or damage. Any devices with signs of corrosion or damage must be discarded and replaced. The PureSet™ Plate is available as a spare part and should be replaced if the plate is discolored or if the legibility of the pictograms or the text is compromised.

#### Sterilization:

1. Pack the assembled PureSet™ Tray (with instruments and plate) in a metal sterilization container, sterilization pouch or single wrap. The metal sterilization container, sterilization pouch or sterilization single wrap should fulfill the following requirements:
  - EN ISO 11607, ST 77 and/or DIN 58953-7.
  - Suitable for steam sterilization (temperature resistance up to at least 137°C (279°F), sufficient steam permeability).
  - Sufficient protection of the instruments as well as of the sterilization packaging to mechanical damage.

**Table 1** presents examples of suitable sterilization containers, pouches, and wraps.

**Table 1: Recommended Sterilization Containers, Pouches, and Wraps for PureSet**

Container/Pouch/Wrap	Description
Sterilization Container	Aesculap® Sterilization Container (Part # JK289)
Sterilization Pouch	Cardinal Health 18"x22" Pouch (Part # 91822)
Sterilization Wrap	Cardinal Health Convertor Brand Bioshield Regular Sterilization Wrap (Part # 4040)

**Note:** The PureSet™ Tray is not intended on its own to maintain sterility; it is intended to be used in conjunction with a legally marketed, validated sterilization container, sterilization pouch or sterilization wrap in order to maintain sterility of the enclosed medical instruments until used.

2. Label the metal sterilization container, sterilization pouch or sterilization wrap with necessary information such as expiration date, lot (if applicable), sterility information, product name with article number.
3. Ensure the PureSet™ Tray is sealed in the sterilization container/pouch/wrap and place into the autoclave/sterilizer. The PureSet™ Tray must be sterilized in its "ready for use" state.
4. Sterilize the devices. Both the gravity displacement cycle and pre-vacuum (top dynamic air removal) cycle can be applied, using the following recommended parameters (**Table 2**):

**Table 2: Recommended Sterilization Cycles**

Cycle	Minimum Temperature	Minimum Sterilization Time	Minimum Drying Time (In Chamber)	Minimum Pressure
Gravity Cycle <sup>1</sup>	132°C (270°F)	15 minutes	20 minutes	≥2868.2 mbar <sup>4</sup>
Pre-Vacuum Cycle <sup>1</sup>	132°C (270°F)	4 minutes		≥3042 mbar <sup>5</sup>
Gravity Cycle <sup>1</sup>	134°C (273°F)	10 minutes		
Pre-Vacuum Cycle <sup>2</sup>	134°C (273°F)	3 minutes		
Pre-Vacuum Cycle <sup>3</sup>	134°C (273°F)	18 minutes		

<sup>1</sup> Validated sterilization processes to achieve a Sterility Assurance Level (SAL) of 10<sup>-6</sup> in accordance to EN ISO 17665-1.

<sup>2</sup> Recommendation of the Welsh Health Technical Memorandum (WHTM) 01-01 Part C.

<sup>3</sup> Recommendation of the World Health Organization (WHO) for steam sterilization of instruments with potential TSE/CJD contamination. Ensure that the packaging and monitoring systems (chemical/biological indicators) used for this cycle are validated for these conditions.

<sup>4</sup> Saturated steam pressure at 132°C as per required by EN ISO 17665-2.

<sup>5</sup> Saturated steam pressure at 134°C as per required by EN ISO 17665-2.

**Caution:** Do not use gravity sterilization if the PureSet™ Tray is sealed in a metal sterilization container.

5. After sterilization of the PureSet™ Tray, inspect the sterilization container, pouch, or wrap to confirm its integrity.

**Note:** At the Point of Use, carefully remove the PureSet™ Tray from the sterilization container, pouch, or wrap. If using a metal sterilization container, avoid hitting the PureSet™ Tray against the inside of container to avoid unintended opening of the lid.

**Note:** Autoclave/sterilizer design and performance can affect the efficacy of the sterilization process. Healthcare facilities should therefore validate the processes that they use, employing the actual equipment and operators that routinely process the devices. All autoclaves/sterilizers should comply with the requirements of, and be validated, maintained and checked in accordance with SN EN 13060, EN 285, EN ISO 17665-1, and/or AAMI ST79, or to the applicable national standard. The autoclave/sterilizer manufacturer's instructions for use must be strictly followed.

#### Storage and Maintenance:

After sterilization, place the sealed PureSet™ Tray in a dry and dark place. Follow the instructions provided by the manufacturer of the metal sterilization container, sterilization pouch, or sterilization wrap regarding the storage conditions and expiration date of the sterilized devices.

#### Containment and Transportation/Shipping to Point of Use:

The container and/or outer packaging used to transport or ship the reprocessed device back to the point of use must be suitable to protect and safeguard the sterility of the devices during transportation, taking the device packaging and the required transportation or shipping process (intrafacility transportation or shipping to an external site) into account.

#### Performance Requirements and Limitations:

To achieve the desired performance, the PureSet™ Tray must only be used with the products described in this Instructions for Use and/or in the Instructions for Use for other compatible Nobel Biocare products, and in accordance with the Intended Use for each product. To confirm the compatibility of products which are intended to be used in conjunction with the PureSet™ Tray, check the color coding, dimensions, lengths, connection type and/or any direct marking as applicable on the products or product labeling.

#### Facilities and Training:

It is strongly recommended that new and experienced users of Nobel Biocare products always go through special training before using a new product for the first time. Nobel Biocare offers a wide range of courses for various levels of knowledge and experience. For more information please visit [www.nobelbiocare.com](http://www.nobelbiocare.com).

**Storage, Handling and Transportation:**

The device must be stored and transported in dry conditions in the original packaging at room temperature and not exposed to direct sunlight. Incorrect storage and transportation may influence device characteristics leading to failure.

**Disposal:**

Safely discard potentially contaminated or no longer usable medical devices as healthcare (clinical) waste in accordance with local healthcare guidelines, country and government legislation or policy. Separation, re-cycling or disposal of packaging material shall follow local country and government legislation on packaging and packaging waste, where applicable.

**Manufacturer and Distributor Information:**

**Manufacturer:**  
Nobel Biocare AB  
Box 5190, 402 26  
Västra Hamngatan 1  
411 17 Göteborg  
Sweden  
[www.nobelbiocare.com](http://www.nobelbiocare.com)

**Distributed in Australia by:**

Nobel Biocare Australia Pty Ltd  
Level 4/7 Eden Park Drive  
Macquarie Park, NSW 2113 Australia  
Phone: +61 1800 804 597

**Distributed in New Zealand by:**

Nobel Biocare New Zealand Ltd  
33 Spartan Road  
Takanini, Auckland, 2105 New Zealand  
Phone: +64 0800 441 657



CE Mark for Class I  
Devices

**Notice Regarding Canadian Device Licensure:** Note that not all products described in this IFU may have been licensed in accordance with Canadian law.

**Basic UDI-DI Information:**

The following table lists the Basic UDI-DI information for the devices described in this IFU.

Product	Basic UDI-DI Number
PureSet™ Tray and Plate	73327470000001436Z

**Symbols Glossary:**

The following symbols may be present on the device labeling or in information accompanying the device. Refer to the device labeling or accompanying information for the applicable symbols.



Authorized representative in the European Community



Batch code



Catalogue number



Caution



CE mark



CE mark with Notified Body number



Consult instructions for use



Contains hazardous substances



Contains or presence of DEHP phthalate



Contains or presence of natural rubber latex



Contains or presence of phthalate



Date



Date of manufacture



Do not re-sterilize



Do not re-use



Do not use if package is damaged



Double sterile barrier system

Rx only

For prescription use only



Health care centre or doctor



Keep away from sunlight



Keep dry

[symbol.glossary.nobelbiocare.com](http://symbol.glossary.nobelbiocare.com)  
[ifu.nobelbiocare.com](http://ifu.nobelbiocare.com)

Link to Online Symbols Glossary and IFU Portal



Magnetic resonance conditional



Magnetic resonance safe



Manufacturer



Medical device



Non-pyrogenic



Non-sterile



Patient identification



Patient information website



Patient number



Serial number



Single sterile barrier system



Single sterile barrier system with protective packaging inside



Single sterile barrier system with protective packaging outside



Sterilized using Ethylene Oxide



Sterilized using irradiation



Sterilized using steam or dry heat



Temperature limit



Tooth number



Unique Device Identifier



Upper limit of temperature



Use-by date

EN All rights reserved.

Nobel Biocare, the Nobel Biocare logotype and all other trademarks used in this document are, if nothing else is stated or is evident from the context in a certain case, trademarks of Nobel Biocare. Product images in this folder are not necessarily to scale. All product images are for illustration purposes only and may not be an exact representation of the product.