

NobelActive® TiUnite™ Implants

Instructions for use



Important – Disclaimer of Liability:

This product is part of an overall concept and may only be used in conjunction with the associated original products according to the instructions and recommendation of Nobel Biocare. Non-recommended use of products made by third parties in conjunction with Nobel Biocare products will void any warranty or other obligation, express or implied, of Nobel Biocare. The user of Nobel Biocare products has the duty to determine whether or not any product is suitable for the particular patient and circumstances. Nobel Biocare disclaims any liability, express or implied, and shall have no responsibility for any direct, indirect, punitive or other damages, arising out of or in connection with any errors in professional judgment or practice in the use of Nobel Biocare products. The user is also obliged to study the latest developments in regard to this Nobel Biocare product and its applications regularly. In cases of doubt, the user has to contact Nobel Biocare. Since the utilization of this product is under the control of the user, they are his/her responsibility. Nobel Biocare does not assume any liability whatsoever for damage arising thereof. Please note that some products detailed in this Instruction for Use may not be regulatory cleared, released or licensed for sale in all markets.

Description:

This Instructions for Use (IFU) describes the Nobel Biocare NobelActive® TiUnite™ Implant and supporting components, including the instrumentation which is required during the surgical and handling procedure to prepare the implant site and to place the implant.

NobelActive® TiUnite™ Implants:

NobelActive® TiUnite™ Implants are endosseous threaded implants available in diameters of 3.0, 3.5, 4.3, 5.0 and 5.5mm. The implants have the following features:

- The NobelActive® TiUnite™ Implant macroshape is characterized by an expanding tapered body, expanding double thread, and drilling blades at apex.
- NobelActive® TiUnite™ Implants feature an internal conical connection (CC) and are available in platform sizes 3.0, Narrow Platform (NP), Regular Platform (RP) and Wide Platform (WP). The implants are compatible with Nobel Biocare restorative components featuring the internal conical connection.
- NobelActive® TiUnite™ Implants feature a TiUnite anodized surface.

Table 1 summarizes the available NobelActive® TiUnite™ Implants based on the platform sizes and color coding. The table presents key dimensional information including platform and implant diameters, abutment interface dimensions, and implant length.

Table 1: NobelActive® Implant Specifications

Platform	Platform diameter	Implant diameter	Abutment interface	Lengths
3.0	Ø 3.0 mm	Ø 3.0 mm	Ø 2.5 mm	10 mm, 11.5 mm, 13 mm, 15 mm
NP	Ø 3.5 mm	Ø 3.5 mm	Ø 3.0 mm	8.5 mm, 10 mm, 11.5 mm, 13 mm, 15 mm, 18 mm
RP	Ø 3.9 mm	Ø 4.3 mm	Ø 3.4 mm	8.5 mm, 10 mm, 11.5 mm, 13 mm, 15 mm, 18 mm
RP	Ø 3.9 mm	Ø 5.0 mm	Ø 3.4 mm	8.5 mm, 10 mm, 11.5 mm, 13 mm, 15 mm, 18 mm
WP	Ø 5.1 mm	Ø 5.5 mm	Ø 4.4 mm	7.0 mm, 8.5 mm, 10 mm, 11.5 mm, 13 mm, 15 mm

Note: The NobelActive® TiUnite™ WP 5.5mm implant is co-packaged with a cover screw. Refer to Nobel Biocare Instructions for Use (IFU) IFU1016 for information regarding cover screws. This IFU is available for download at ifu.nobelbiocare.com.

Instrumentation:

The following instrumentation is required during the surgical and handling procedures to place NobelActive® TiUnite™ Implants:

- The Guide Drill, Precision Drill, Twist Drills, and Twist Step Drills, are required to prepare the osteotomy for placement of NobelActive® TiUnite™ Implants. Twist Drills and Twist Step Drills are available in different diameters and lengths in order to widen the osteotomy step-by-step to the appropriate diameter and depth.
- Screw Taps NobelActive 3.0/NP/RP/WP can be used to cut threads in an osteotomy in dense bone.
- The Depth Probe 7-18 mm Z-shaped is used to verify the depth of the osteotomy. Refer to Nobel Biocare IFU1090 for information regarding the Depth Probe 7-18 mm Z-shaped.
- Implant Drivers Conical Connection 3.0/NP/RP/WP must be used to place NobelActive® TiUnite™ Implants. Refer to Nobel Biocare IFU1058 for information regarding the implant drivers.

Caution: The implant drivers, healing abutments, and prosthetic components, as well as the cover screw for the NobelActive® TiUnite™ WP 5.5 mm implant, are color-coated according to Table 1 in order to indicate the compatible implant diameter and platform size (3.0, NP, RP, WP). The NobelActive® TiUnite™ Implant packaging also is color-coded; however, it is important to note that the implants themselves do not have color-coating, with the exception of WP 5.5 mm (blue).

Intended Use / Intended Purpose:

NobelActive® TiUnite™ Implants:

Intended for use as an endosseous dental implant in the maxilla or mandible for anchoring or supporting dental prostheses to restore chewing function.

Guide Drill, Precision Drill, Twist Drills, Twist Step Drills, and Screw Taps Nobel Active:

Intended for use to prepare or support the preparation of an osteotomy for placement of an endosseous dental implant.

Indications:

NobelActive® TiUnite™ Implants:

NobelActive® TiUnite™ Implants are indicated to support restorations ranging from single tooth to fixed-removable full arch dental procedures to restore chewing function. This can be achieved by a 2-stage or 1-stage surgical technique in combination with immediate, early or delayed loading protocols, recognizing sufficient primary stability and appropriate occlusal loading for the selected technique.

NobelActive® TiUnite™ 3.0 Implants are indicated for single unit restorations only, to replace a lateral incisor in the maxilla and/or a central or lateral incisor in the mandible.

Guide Drill and Precision Drill:

The Guide Drill and Precision Drill are indicated for use in the maxilla or mandible to prepare the entrance point for an osteotomy prior to implant placement.

Twist Drills and Twist Step Drills:

Twist Drills and Twist Step Drills are indicated for use in the maxilla or mandible to prepare an osteotomy for the placement of a dental implant.

Screw Taps NobelActive:

Screw Taps NobelActive are indicated for use in the maxilla or mandible to prepare an osteotomy in dense bone for placement of NobelActive® TiUnite™ Implants.

Contraindications:

It is contraindicated to use NobelActive® TiUnite Implants, cover screws, and tooling in:

- Patients who are medically unfit for an oral surgical procedure.
- Patients with inadequate bone volume unless an augmentation procedure can be considered.
- Patients in whom adequate sizes, numbers or desirable positions of implants are not reachable to achieve safe support of functional or eventually parafunctional loads.
- Patients who are allergic or hypersensitive to commercially pure titanium (grade 4), titanium alloy Ti-6AL-4V, stainless steel, or DLC (Diamond Like Carbon) coating.

NobelActive® TiUnite™ 3.0 Implants are contraindicated to replace a central incisor, canine, premolar or molar in the maxilla, as well as to replace a canine, premolar or molar in the mandible.

NobelActive® TiUnite™ 3.0 Implants are contraindicated for multiple tooth replacements.

Refer to Nobel Biocare IFU1016 for contraindications specific to the cover screws.

Warnings:

Failure to recognize actual lengths of drills relative to radiographic measurements can result in permanent injury to nerves or other vital structures. Drilling beyond the depth intended for lower jaw surgery may potentially result in permanent numbness to the lower lip and chin or lead to a hemorrhage in the floor of the mouth.

Besides the mandatory Precautions for any surgery such as asepsis, during drilling in the jaw bone, one must avoid damage to nerves and vessels by referring to anatomical knowledge and preoperative radiographs.

Cautions:

General:

One hundred percent implant success cannot be guaranteed. In particular, non-observance of the product's indications for use and the surgical/handling procedure(s) may result in failure.

Treatment by means of implants may lead to loss of bone, biologic or mechanical failures including fatigue fracture of implants.

Close cooperation between surgeon, restorative dentist and dental laboratory technician is essential for a successful implant treatment.

It is strongly recommended that NobelActive® TiUnite™ Implants are used only with compatible Nobel Biocare instruments and components. Use of instruments or components that are not intended to be used in combination with NobelActive® TiUnite™ Implants can lead to product failure, damage to tissue, or unsatisfactory esthetic results.

When using a new device/treatment method for the first time, working with a colleague who is experienced with the new device/treatment method may help avoid possible complications. Nobel Biocare has a global network of mentors available for this purpose.

Before Surgery:

Careful psychological and physiological evaluation, followed by clinical and radiological examination must be performed on the patient prior to surgery to determine the suitability of the patient for treatment.

Special attention has to be given to patients who have local or systemic factors that could interfere with the healing process of either bone or soft tissue or the osseointegration process (e.g., cigarette smoking, poor oral hygiene, uncontrolled diabetes, oro-facial radiotherapy, steroid therapy, infections in the neighboring bone). Special caution is advised in patients who receive bisphosphonate therapy.

In general, implant placement and prosthetic design must accommodate individual patient conditions. In case of bruxism, other parafunctional habits or unfavorable jaw relationships, reappraisal of the treatment option may be considered.

The device has not been evaluated in pediatric/adolescent patients and is not recommended for use in children. Routine treatment is not recommended until the end of the juvenile jaw bone growth phase has been properly documented.

Pre-operative hard tissue or soft tissue deficits may yield a compromised esthetic result or unfavorable implant angulations.

All components, instruments and tooling used during the clinical and laboratory procedure must be maintained in good condition and care must be taken that instrumentation does not damage implants or other components.

At Surgery:

Particular caution should be used when placing narrow platform implants in the posterior region due to risk of prosthetic overload.

Care and maintenance of sterile instruments are crucial for a successful treatment. Sterilized instruments not only safeguard your patients and staff against infection but are also essential for the outcome of the total treatment.

Because of the small sizes of the devices, care must be taken that they are not swallowed or aspirated by the patient. It is appropriate to use specific supporting tools to prevent aspiration of loose parts (e.g. a throat shield).

The implants may be tilted up to 45° relative to the occlusal plane. When used with angulations between 30° and 45°, the following applies: The tilted implant must be splinted; a minimum of 4 implants must be used when supporting a fixed prosthesis in a fully edentulous arch.

After the implant installation, the surgeon's evaluation of bone quality and primary stability will determine when implants may be loaded. Lack of adequate quantity and/or quality of remaining bone, infection and generalized diseases may be potential causes for failure of osseointegration both immediately after surgery, or after osseointegration is initially achieved.

After Surgery:

To help ensure a successful long term-treatment outcome, it is advised to provide comprehensive regular patient follow up after implant treatment and to inform the patient about appropriate oral hygiene.

Intended Users and Patient Groups:

NobelActive® TiUnite™ Implants and instrumentation are to be used by dental health care professionals.

NobelActive® TiUnite™ Implants and instrumentation are to be used in patients subject to dental implant treatment.

Clinical Benefits and Undesirable Side Effects:

Clinical Benefits Associated with NobelActive® TiUnite™ Implants and Instrumentation:

NobelActive® TiUnite™ Implants and instrumentation are a component of treatment with a dental implant system and/or dental crowns and bridges. As a clinical benefit of treatment, patients can expect to have their missing teeth replaced and/or crowns restored.

Undesirable Side Effects Associated with NobelActive® TiUnite™ Implants and Instrumentation:

The placement of a dental implant constitutes an invasive treatment which may be associated with typical side effects such as inflammation, infection, bleeding, hematoma, pain, and swelling. Depending on the location, placement of the implant may also lead (in rare cases) to bone fracture, perforation of neighboring structures, sinusitis, or sensory/motor disturbances. During placement of this device the pharyngeal (gag) reflex may be triggered in patients with a sensitive gag reflex.

During use of the instrumentation, the pharyngeal (gag) reflex may be triggered in patients with a sensitive gag reflex.

Dental implants are the substructure of a multi-component system that replaces teeth and as a result, the implant recipient may experience side effects similar to those associated with teeth, such as mucositis, calculus, peri-implantitis, fistulas, ulcers, soft tissue hyperplasia, soft and/or hard tissue recession/loss. Some patients may experience discoloration in the mucosal area, such as graying.

Where required per the European Medical Device Regulation (MDR; EU 2017/745) a Summary of Safety and Clinical Performance document (SSCP) is available for the NobelActive® TiUnite™ Implants. The SSCP can be obtained at the following website:

<https://ec.europa.eu/tools/eudamed/>

¹ Website available upon launch of the European Database on Medical Devices (EUDAMED)

Notice regarding serious incidents:

For a patient/user/third party in the European Union and in countries with an identical regulatory regime (Regulation 2017/745/EU on Medical Devices); if, during the use of this device or as a result of its use, a serious incident has occurred, please report it to the manufacturer and to your national authority. The contact information for the manufacturer of this device to report a serious incident is as follows:

Nobel Biocare AB

<https://www.nobelbiocare.com/complaint-form>

Surgical Procedure:

During drilling procedures bone quality should be considered. Refer to Table 2, which presents the recommended drill sequences based on bone quality to ensure optimal primary stability when applying immediate function.

The recommended drill sequences are based on bone quality. Drill data are stated in mm and the drill diameters listed within brackets denote widening of cortex only.

Table 2: Recommended Drill Sequences Based on Bone Quality

Platform	Ø Implant	Soft bone Type IV	Medium bone Type II-III	Dense bone Type I
3.0	3.0 mm	1.5	2.0	2.0 2.4/2.8
NP	3.5 mm	2.0 (2.4/2.8)	2.0 2.4/2.8 (2.8/3.2)	2.0 2.4/2.8 2.8/3.2
RP	4.3 mm	2.0 2.4/2.8 (2.8/3.2)	2.0 2.4/2.8 3.2/3.6	2.0 2.4/2.8 3.2/3.6 (3.8/4.2)
RP	5.0 mm	2.0 2.4/2.8 3.2/3.6	2.0 2.4/2.8 3.2/3.6 3.8/4.2	2.0 2.4/2.8 3.2/3.6 3.8/4.2 (4.2/4.6)
W/P	5.5 mm	2.0 2.4/2.8 3.2/3.6 (3.8/4.2)	2.0 2.4/2.8 3.2/3.6 3.8/4.2 4.2/4.6 (4.2/5.0)	2.0 2.4/2.8 3.2/3.6 3.8/4.2 4.2/5.0 Screw Tap

Drilling must proceed at high speed (max. 2000 rpm for Twist Step/ Drills) under constant and profuse external irrigation by sterile saline at room temperature.

Depth measurement system: the parallel drills have a true depth measurement system. All drills and components are marked to prepare the site to the correct depth and obtain a secure and predictable position.

Drills are available for implant lengths (laser marks) of 7-10, 7-15 and 10-18 mm. The correct diameter and length of the drills is indicated on the label.

Note: The actual implant length is 0.5 mm shorter than the indicated name.

Caution: Twist Drills and Twist Step Drills extend up to 1 mm longer than the implant when seated. Allow for this additional length when drilling near vital anatomical structures (refer to **Figure A** for drill reference lines).

Caution: There are no laser marks for 8.5 mm and 11.5 mm implant lengths. The 8.5 mm is between the 7 mm and 10 mm laser mark. The 11.5 mm is between the 10 mm and 13 mm laser mark (refer to **Figure A** for drill reference lines).

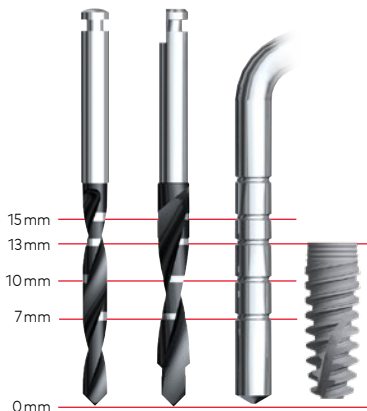

Figure A: Twist Drills and Twist Step Drills 7-15 mm and Implant 13 mm

Note: The marks on Twist Drills and Twist Step Drills indicate actual millimeter length and correspond to the implant collar. Final vertical positioning depends on several parameters, including esthetics, tissue thickness and available vertical space.

1. Prepare implant site (**Figure B**). When using a flapless approach add-on soft tissue height to drill depth.
2. Measure the final depth of implant site for applicable implant length using depth probe with same measurements as Twist Drills and Twist Step Drills.
3. Open the implant package and pick up the implant from inner casing by applying light pressure on the implant driver (3.0, NP, RP, W/P) and carefully turn the implant sleeve counter clockwise until implant driver is fully seated (**Figure C**).

NobelActive® TiUnite™ Implants are ideally installed with low speed, maximum 25 rpm, using a handpiece or by hand using the surgical driver and corresponding implant driver (3.0, NP, RP, W/P).

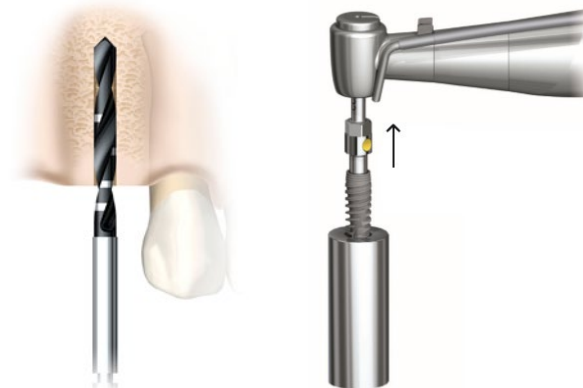

Figure B: Preparation of Implant Site

Figure C: Seating the Implant Driver

4. Place and tighten the implant. For NobelActive® TiUnite™ Implants 3.0 use maximum 45 Ncm installation torque and for NobelActive® TiUnite™ Implants 3.5, 4.3, 5.0 and 5.5 use maximum 70 Ncm installation torque (**Figure D**). To facilitate proper orientation, see markings on implant drivers (**D1** and **D2** in **Figure D**).

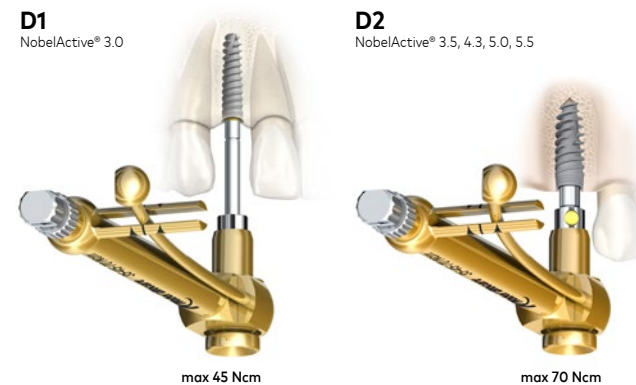

Figure D: Placement and Tightening of Implant

Note: The double lead thread allows NobelActive® TiUnite™ Implants to be inserted faster compared to other implants. This means that less turns are required to fully seat the implant.

Caution: Never exceed insertion torque of **45 Ncm** for a NobelActive® TiUnite™ 3.0 Implant and **70 Ncm** for NobelActive® TiUnite™ 3.5, 4.3, 5.0 and 5.5 Implants. Overtightening an implant may lead to damage of the implant, fracture or necrosis of the bone site. If a Surgical Driver is used to insert the implant, special care needs to be taken to avoid over tightening.

Caution: The unique thread design of NobelActive® TiUnite™ Implants allows to redirect the implant during insertion. This feature requires special attention to execute during placement, as the implant will not necessarily stop at the bottom of the prepared site but may go deeper into the bone (refer to **Figure E**).

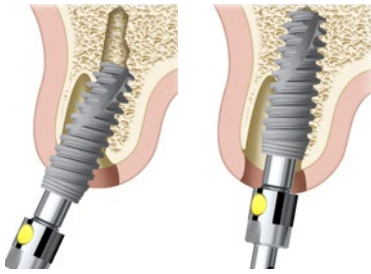

Figure E: Redirection of the Implant During Insertion

Special instructions when placing NobelActive® TiUnite™ 3.0 implants:

Insertion torque for NobelActive® TiUnite™ 3.0: Due to the narrow implant diameter and narrow implant abutment connection the maximum insertion torque for NobelActive® TiUnite™ 3.0 differs from the entire NobelActive® TiUnite™ assortment.

Caution: Never exceed insertion tightening torque of 45 Ncm for the implant and 15 Ncm prosthetic tightening torque for the abutment screw. Overtightening of implant may lead to damage of the implant, fracture or necrosis of the bone site. Overtightening of the abutment screw may lead to screw fracture.

Procedure for Implant Placement in Dense Bone:

If the implant gets stuck during implant installation, or the maximum torque is achieved before fully seated (**45 Ncm** for NobelActive® TiUnite™ 3.0 or **70 Ncm** for NobelActive® TiUnite™ 3.5, 4.3, 5.0, and 5.5), one of the following procedures should be followed:

- Rotate the implant counter clockwise for a few turns enabling the use of the self-tapping capacity of the implant; or
 - Back out implant and widen the site with a wider drill according to drill protocol; or
 - Select a NobelActive® Screw Tap which matches the diameter of the implant and desired drilling depth (refer to **Figure F**).
- Place screw tap into prepared implant site using low speed (25 rpm).
 - Apply firm pressure and begin rotating the screw tap slowly. When the threads engage, continue to thread the screw tap to the defined depth without applying additional pressure.
 - Switch the drill unit with handpiece to reverse mode and back the screw tap out.

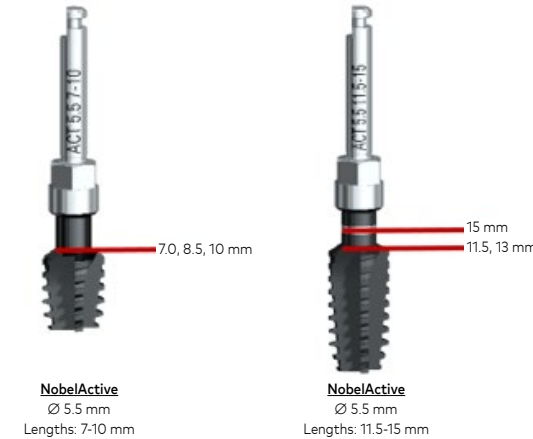
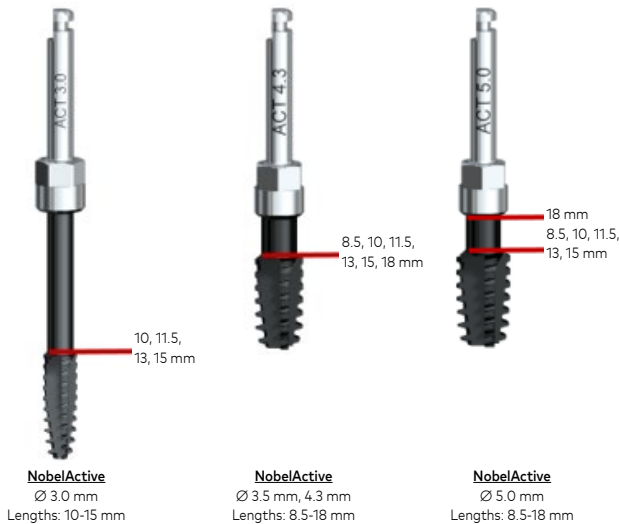

Figure F: Screw Taps for Installation of NobelActive® Implants in Dense Bone

- Continue with implant installation until desired position is achieved using max 45 Ncm installation torque for NobelActive® TiUnite™ 3.0 implant or max 70 Ncm for NobelActive® TiUnite™ 3.5, 4.3, 5.0, and 5.5 Implants.
- When placing the implant, align one of the black hex indicators on the implant driver parallel to the buccal wall (refer to **G1** in **Figure G**). This ensures that one of the flat sides of the hexagon is parallel to the buccal side, ensuring preferred prosthetic abutment orientation (refer to **G2** in **Figure G**).

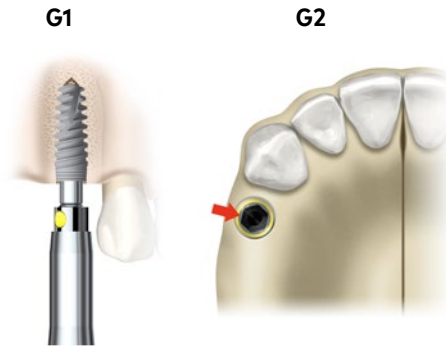

Figure G: Final Implant Placement (G1) and Alignment (G2)

- For Immediate Function, the implant should be able to withstand a final torque of 35–45 Ncm for NobelActive® TiUnite™ 3.0 implant and 35–70 Ncm for NobelActive® TiUnite™ 3.5, 4.3, 5.0, and 5.5 implants.
- Depending on the surgical protocol of choice, place a cover screw (refer to **G1** in **Figure H**), healing abutment (refer to **H2** in **Figure H**) or a provisional restoration in case of immediate loading approach.

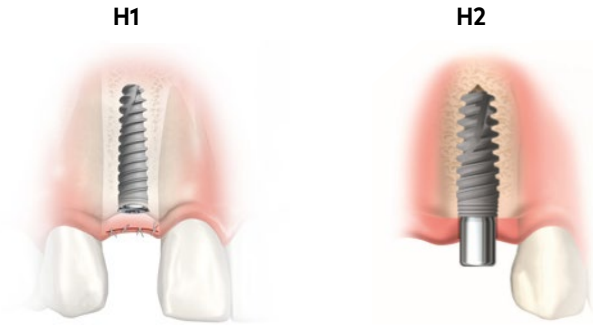

Figure H: Placement of a cover screw (H1) or healing abutment (H2)

Materials:

- NobelActive® TiUnite™ Implant: Commercially pure titanium grade 4 according to ASTM F67
- Cover screw: Titanium alloy Ti-6AL-4V (90% titanium, 6% aluminum, 4% vanadium) per ASTM F136 and ISO 5832-3.
- Twist Drills, Twist Step Drills and Screw Taps: Stainless steel, DLC (Diamond Like Carbon) coating per 1.4197 Type 420F Mod according to ASTM A895 and ISO 5832-1.
- Guide Drill and Precision Drill: Stainless steel 1.4197 according to ASTM F899.

Sterility and Reusability Information:

NobelActive® TiUnite™ Implants, Guide Drill, Precision Drill, Twist Drills, Twist Step Drills and Cover Screws have been sterilized using irradiation and are intended for single use only. Do not use after the labeled expiration date.

Warning: Do not use device if the packaging has been damaged or previously opened.

Caution: NobelActive® TiUnite™ Implants, Guide Drill, Precision Drill, Twist Drills, Twist Step Drills and Cover Screws are for single use and must not be reprocessed. Reprocessing could cause loss of mechanical, chemical and / or biological characteristics. Reuse could cause local or systemic infection.

Screw Taps NobelActive® have been sterilized using irradiation and are intended for reuse. Do not use after the labeled expiration date. Prior to reuse clean and sterilize the product following the manual or automated procedure in the Cleaning and Sterilization Instructions.

Screw Taps NobelActive® are re-usable devices which shall be inspected before each re-use to ensure that the integrity and performance continues to be maintained. Please check if any wear deformation or corrosion is visible on the screw tap. In particular, if any corrosion or deformation is visible, the screw tap shall be discarded.

Nobel Biocare recommends that Screw Taps NobelActive® are replaced after 20 uses, or when cutting efficiency declines. Worn-out or damaged screw taps must be discarded and replaced with new, sharp screw taps. Over use may cause bone overheating and lead to implant failure.

Warning: Do not use device if the packaging has been damaged or previously opened.

Warning: Use of non-sterile device may lead to infection of tissues or infectious diseases.

Cleaning and Sterilization Instructions:

Screw Taps NobelActive® are delivered sterile by Nobel Biocare and are intended for reuse. Prior to each use, the devices must be cleaned and sterilized by the user.

The devices can be cleaned manually, or in an automatic washer. Each device must then be individually sealed in a sterilization pouch and sterilized.

The following cleaning and sterilization processes have been validated according to international standards and guidelines as applicable:

- Manual and Automated Cleaning: AAMI TIR 12.
- Sterilization: AAMI ST79 and ISO 17665-1.

According to EN ISO 17664, it is the responsibility of the user/processor to ensure that the processing/reprocessing is performed using equipment, materials and personnel which are suitable to ensure the effectiveness of the processes. Any deviation from the following instructions should be validated by the user/processor to ensure the effectiveness of the process.

Note: The manufacturer's instructions for use for any detergent / cleaning solution and/or equipment and accessories used to clean and/or dry the device(s) must be strictly followed where applicable.

Note: The Screw Taps NobelActive® have been validated to withstand these cleaning and sterilization procedures.

Initial Treatment at Point of Use Prior to Reprocessing:

1. Discard single-use instruments and worn reusable instruments immediately after use.
2. Remove excess soil and debris from reusable devices to be reprocessed using absorbent paper wipes.
3. Rinse the devices with cold running tap water.

Containment and Transportation/Shipping to Reprocessing Area:

1. After removal of excess soil and debris, store the devices in a container which is suitable to protect the devices during transportation and to avoid any contamination of personnel or the environment.
2. Transport the devices to the reprocessing area as soon as practical. If transfer to the processing area is likely to be delayed, consider covering the devices with a damp cloth or store it in a closed container to avoid drying of soil and/or debris.

Note: Reusable devices should be reprocessed by initiating the prescribed automated or manual cleaning and drying procedures within 1 hour of use, to ensure the efficacy of the reprocessing.

3. If the devices are shipped to an outside facility for reprocessing, they must be contained in a transportation or shipping container which is suitable to protect the devices during transportation and to prevent contamination of personnel or the environment.

Automated Cleaning and Drying (Including Pre-cleaning):

Pre-cleaning:

1. Immerse the device in 0.5% lukewarm enzymatic cleaning agent (e.g. Neodisher Medizym) for a minimum of 5 minutes.
2. Fill lumina (where applicable) with 0.5% lukewarm enzymatic cleaning agent (e.g. Neodisher Medizym) using a 20 ml syringe.
3. Brush the outer surfaces with a soft bristled nylon brush (e.g. Medsafe MED-100.33) for a minimum of 20 seconds until all visible soil is removed.
4. Brush the inner surfaces, lumina and cavities (where applicable) with an appropriately sized bottle brush (e.g. 1.2 mm / 2.0 mm / 5.0 mm diameter) for a minimum of 20 seconds until all visible soil is removed.
5. Thoroughly rinse all outer and inner surfaces, lumina and cavities (where applicable) with cold running tap water for a minimum of 10 seconds to remove all cleaning solution.
6. Rinse lumina (where applicable) with 20 ml tap water using a 20 ml syringe.

Automated Cleaning and Drying:

The following washer was used in the Nobel Biocare validation: Miele G7836 CD with the Vario TD program.

Note: It is recommended to perform the automated cleaning and drying with a maximum load of 11 individual devices.

1. Place the devices in a suitable rack or load carrier (e.g. metal sieve basket).
2. Load the devices into the washer. Ensure the rack or load carrier is oriented in a horizontal position.
3. Perform automatic cleaning. The following parameters are based on the Vario TD program on the Miele G7836 CD washer:
 - Minimum 2 minutes pre-cleaning with cold tap water.
 - Draining.
 - Minimum 5 minutes cleaning with minimum 55°C (131°F) tap water and 0.5% mildly alkaline detergent (e.g. Neodisher Mediclean).
 - Draining.
 - Minimum 3 minutes neutralization with cold desalinated water.
 - Draining.
 - Minimum 2 minutes rinsing with cold desalinated water.
 - Draining.
4. Run drying cycle at minimum 50°C (122°F) for a minimum of 10 minutes.
5. Dry with compressed air or clean and lint-free single use wipes, if any residual moisture remains after the drying cycle.

Visual Inspection:

After cleaning and drying, inspect the device for unacceptable deterioration such as corrosion, discoloration, pitting, or cracked seals and properly discard any devices that fail the inspection.

Manual Cleaning and Drying:

1. Immerse device for a minimum of 5 minutes in a sterile 0.9% NaCl solution.
2. Scrub the outer surfaces of the device with soft-bristled nylon brush for a minimum of 20 seconds until all visible soil is removed.
3. Flush the inner surfaces, lumina and cavities (where applicable) with 20 ml lukewarm enzymatic cleaning solution (e.g. Cidezyme ASP; maximum 45°C (113°F)) using an irrigation needle connected to a 20 ml syringe.

4. Brush the inner surfaces, lumina and cavities (where applicable) with appropriately sized bottle brush (e.g. 1.2 mm / 2.0 mm / 5.0 mm diameter) for a minimum of 10 seconds until all visible soil is removed.
5. Thoroughly rinse the outer surfaces and lumina of the device with cold running tap water for a minimum of 10 seconds to remove all cleaning solution.
6. Immerse the device in an ultrasonic bath (e.g. Bandelin; frequency 35 kHz; effective ultrasonic power 300 W) containing 0.5% enzymatic cleaning agent (e.g. Cidezyme ASP) and treat for a minimum of 5 minutes at minimum 40°C (104°F) / maximum 45°C (113°F).
7. Flush the inner surfaces, lumina and cavities (where applicable) with 20ml lukewarm tap water using an irrigation needle connected to a 20ml syringe.
8. Thoroughly rinse the outer surfaces of the device with purified or sterile water for a minimum of 10 seconds to remove all cleaning agent.
9. Dry with compressed air or clean and lint-free single use wipes.

Visual Inspection:

After cleaning and drying, inspect the device for unacceptable deterioration such as corrosion, discoloration, pitting, cracked seals and properly discard any devices that fail the inspection.

Sterilization:

The following steam sterilizers were used in the Nobel Biocare validation: Systec HX -320 (pre-vacuum cycle); Amsco Century Sterilizer (gravity cycle).

Note: It is recommended to perform sterilization with a maximum load of 11 devices individually sealed in sterilization pouches.

1. Seal each device in a suitable sterilization pouch. The sterilization pouch should fulfill the following requirements:
 - EN ISO 11607 and/or DIN 58953-7.
 - Suitable for steam sterilization (temperature resistance up to at least 137°C (279°F), sufficient steam permeability).
 - Sufficient protection of the instruments as well as of the sterilization packaging to mechanical damage.

Table 3 presents examples of suitable sterilization containers, pouches, and wraps.

Table 3: Recommended Sterilization Pouches

Method	Recommended Sterilization Pouch
Gravity Cycle	SPSmedical Self-Seal sterilization pouch
Pre-vacuum Cycle	SteriCLIN® pouch

2. Label the sterilization pouch with information necessary to identify the device (for example, the product name with article number and lot/batch number (if applicable)).
3. Place the sealed sterilization pouch into the autoclave/sterilizer. Ensure that the sterilization pouch is oriented in a horizontal position.
4. Sterilize the device. Both the gravity displacement cycle and pre-vacuum (top dynamic air removal) cycle can be applied, using the following recommended parameters (Table 4):

Table 4: Recommended Sterilization Cycles

Cycle	Minimum Temperature	Minimum Sterilization Time	Minimum Drying Time (In Chamber)	Minimum Pressure
Gravity Cycle ¹	132°C (270°F)	15 minutes	20 minutes	≥2868.2 mbar ⁴
Pre-Vacuum Cycle ¹	132°C (270°F)	4 minutes		
Pre-Vacuum Cycle ²	134°C (273°F)	3 minutes	20 minutes	≥3042 mbar ⁵
Pre-Vacuum Cycle ³	134°C (273°F)	18 minutes		

⁴ Validated sterilization processes to achieve a Sterility Assurance Level (SAL) of 10⁻⁶ in accordance to EN ISO 17665-1.

⁵ Recommendation of the Welsh Health Technical Memorandum (WHTM) 01-01 Part C.

⁶ Recommendation of the World Health Organization (WHO) for steam sterilization of instruments with potential TSE/CJD contamination. Ensure that the packaging and monitoring systems (chemical/biological indicators) used for this cycle are validated for these conditions.

⁷ Saturated steam pressure at 132°C as per required by EN ISO 17665-2.

⁸ Saturated steam pressure at 134°C as per required by EN ISO 17665-2.

Note: Autoclave/sterilizer design and performance can affect the efficacy of the sterilization process. Healthcare facilities should therefore validate the processes that they use, employing the actual equipment and operators that routinely process the devices. All autoclaves/sterilizers should comply with the requirements of, and be validated, maintained and checked in accordance to SN EN 13060, EN 285, EN ISO 17665-1, and/or AAMI ST79, or to the applicable national standard. The autoclave/sterilizer manufacturer's instructions for use must be strictly followed.

Storage and Maintenance:

After sterilization, place the labeled and sealed sterilization pouch in a dry and dark place. Follow the instructions provided by the manufacturer of the sterilization pouch regarding the storage conditions and expiration date of the sterilized device.

Containment and Transportation/Shipping to Point of Use:

The container and/or outer packaging used to transport or ship the reprocessed device back to the point of use must be suitable to protect and safeguard the sterility of the devices during transportation, taking the device packaging and the required transportation or shipping process (intrafacility transportation or shipping to an external site) into account.

Magnetic Resonance (MR) Safety Information:

NobelActive® TiUnite™ Implants contain metallic materials which can be affected by MRI scanning. Non-clinical testing performed by Nobel Biocare has demonstrated that NobelActive® TiUnite™ Implants are unlikely to impact patient safety under the following MRI conditions:

- Static magnetic field of 1.5 Tesla and 3.0 Tesla only.
- Maximum spatial gradient magnetic field of 4000 Gauss/cm (40 T/m).
- Maximum MR system reported, whole body averaged specific absorption rate (SAR) of 2 W/kg (Normal Operating Mode) or 4 W/kg (First Level Controlled Mode).

Note: Removable restorations should be taken out prior to scanning, as is done for watches, jewelry etc.

Under the conditions defined above, these devices are expected to produce a maximum temperature rise of 4.1°C (39.4°F) after 15 minutes of continuous scanning.

In the non-clinical testing, the image artifact caused by the devices extends approximately 30 mm from the device when imaged with a gradient echo pulse sequence and a 3.0 Tesla MRI system.

Note: Although the non-clinical testing demonstrates that NobelActive® TiUnite™ Implants are unlikely to interfere with patient safety under the conditions defined above, this testing is insufficient to support a claim of MR Safe or MR Conditional for the devices.

Performance Requirements and Limitations:

To achieve the desired performance, NobelActive® TiUnite Implants and instrumentation must only be used with the products described in this Instructions for Use and/or in the Instructions for Use for other compatible Nobel Biocare products, and in accordance with the Intended Use for each product. To confirm the compatibility of products which are intended to be used in conjunction with NobelActive® TiUnite Implants and instrumentation, check the color coding, dimensions, lengths, connection type and/or any direct marking as applicable on the products or product labeling.

Facilities and Training:

It is strongly recommended that new and experienced users of Nobel Biocare products always go through special training before using a new product for the first time. Nobel Biocare offers a wide range of courses for various levels of knowledge and experience. For more information please visit www.nobelbiocare.com.

Storage, Handling and Transportation:

The device must be stored and transported in dry conditions in the original packaging at room temperature and not exposed to direct sunlight. Incorrect storage and transportation may influence device characteristics leading to failure.

Disposal:

Safely discard potentially contaminated or no longer usable medical devices as healthcare (clinical) waste in accordance with local healthcare guidelines, country and government legislation or policy.

Separation, re-cycling or disposal of packaging material shall follow local country and government legislation on packaging and packaging waste, where applicable.

Manufacturer and Distributor Information:

Manufacturer:
 Nobel Biocare AB
 Box 5190, 402 26
 Västra Hamngatan 1
 411 17 Göteborg
 Sweden
www.nobelbiocare.com

Distributed in Australia by:
 Nobel Biocare Australia Pty Ltd
 Level 4/7 Eden Park Drive
 Macquarie Park, NSW 2114 Australia
 Phone: +61 1800 804 597

Distributed in New Zealand by:
 Nobel Biocare New Zealand Ltd
 33 Spartan Road
 Takarangi, Auckland, 2105 New Zealand
 Phone: +64 0800 441 657



Notice Regarding Canadian Device Licensure: Note that not all products described in this IFU may have been licensed in accordance with Canadian law.

Basic UDI-DI Information:

The following table lists the Basic UDI-DI information for the devices described in this IFU.

Product	Basic UDI-DI Number
NobelActive® TiUnite™ Implants	73327470000001216P
Guide Drill, Precision Drill, Twist Drills and Twist Step Drills	73327470000001206M
Screw Taps NobelActive 3.0/NP/RP/WP	73327470000001226R

Implant Card:

NobelActive® TiUnite™ Implants are accompanied by an Implant Card which contains important information for patients regarding the device.

Complete the Implant Card by filling it out with the patient- and device-specific information as indicated and provide the completed Implant Card to the patient.

Symbols Glossary:

The following symbols may be present on the device labeling or in information accompanying the device. Refer to the device labeling or accompanying information for the applicable symbols.



Authorized representative in the European Community



Batch code



Catalogue number



Caution



Sterilized using ethylene oxide



Sterilized using irradiation



Temperature limit



Tooth number



CE marking



Consult instructions for use



Contains hazardous substances



Contains or presence of phthalate



Upper limit of temperature



Sterilized using steam or dry heat



Unique Device Identifier



Use-by date

EN All rights reserved.

Nobel Biocare, the Nobel Biocare logotype and all other trademarks used in this document are, if nothing else is stated or is evident from the context in a certain case, trademarks of Nobel Biocare. Product images in this folder are not necessarily to scale. All product images are for illustration purposes only and may not be an exact representation of the product.



Date



Date of manufacture



Do not re-sterilize



Do not re-use



Do not use if package is damaged



Double sterile barrier system

Rx Only

For prescription use only



Health care centre or doctor



Keep away from sunlight



Keep dry

symbol.glossary.nobelbiocare.com/ifu.nobelbiocare.com

Link to Online Symbols Glossary and IFU Portal



Magnetic resonance conditional



Manufacturer



Medical device



Non-pyrogenic



Non-sterile



Patient identification



Patient information website



Patient number



Serial number



Single sterile barrier system



Single sterile barrier system with protective packaging inside



Single sterile barrier system with protective packaging outside