

NobelParallel™ Conical Connection TiUltra™

Instructions for use



Important: Please read.

Disclaimer of liability:

This product is part of an overall concept and may only be used in conjunction with the associated original products according to the instructions and recommendation of Nobel Biocare. Non-recommended use of products made by third parties in conjunction with Nobel Biocare products will void any warranty or other obligation, express or implied, of Nobel Biocare. The user of Nobel Biocare products has the duty to determine whether or not any product is suitable for the particular patient and circumstances. Nobel Biocare disclaims any liability, express or implied, and shall have no responsibility for any direct, indirect, punitive or other damages, arising out of or in connection with any errors in professional judgment or practice in the use of Nobel Biocare products. The user is also obliged to study the latest developments in regard to this Nobel Biocare product and its applications regularly. In cases of doubt, the user has to contact Nobel Biocare. Since the utilization of this product is under the control of the user, it is his/her responsibility. Nobel Biocare does not assume any liability whatsoever for damage arising thereof. Please note that some products detailed in this Instructions For Use may not be regulatory cleared, released or licensed for sale in all markets.

Description:

Implant:

NobelParallel™ Conical Connection (CC) TiUltra™ dental implants are made from biocompatible commercially pure grade 4 titanium with TiUltra™ surface.

Intended use:

NobelParallel™ CC TiUltra™ implants are intended to be used in the upper or lower jaw bone (osseointegration) and used for anchoring or supporting tooth replacements to restore chewing function.

Indications:

NobelParallel™ CC TiUltra™ implant restorations range from single tooth to fixed-removable full dental arch overdenture applications to restore chewing function.

This can be achieved by a 2-stage or 1-stage surgical technique in combination with immediate, early or delayed loading protocols, recognizing sufficient primary stability and appropriate occlusal loading for the selected technique.

Implants allow also for bi-cortical anchorage in cases of reduced bone density to obtain high initial stability.

Contraindications:

It is contraindicated placing NobelParallel™ CC TiUltra™ implants in:

- Patients who are medically unfit for an oral surgical procedure.
- Patients with inadequate bone volume unless an augmentation procedure can be considered.
- Patients in whom adequate sizes, numbers or desirable positions of implants are not reachable to achieve safe support of functional or eventually parafunctional loads.
- Patients who are allergic or hypersensitive to commercially pure titanium (grade 4), sodium dihydrogen phosphate (NaH₂PO₄) or magnesium chloride (MgCl₂).

Warnings:

Failure to recognize actual lengths of drills relative to radiographic measurements can result in permanent injury to nerves or other vital structures. Drilling beyond the depth intended for lower jaw surgery may potentially result in permanent numbness to the lower lip and chin or lead to a hemorrhage in the floor of the mouth.

Besides the mandatory precautions for any surgery such as asepsis, during drilling in the jaw bone, one must avoid damage to nerves and vessels by referring to anatomical knowledge and preoperative radiographs.

Cautions:

General:

One hundred percent implant success cannot be guaranteed. Especially, non-observance of the indicated limitations of use and working steps may result in failure.

Treatment by means of implants may lead to loss of bone, biologic or mechanical failures including fatigue fracture of implants.

Close cooperation between surgeon, restorative dentist and dental laboratory technician is essential for a successful implant treatment.

It is strongly recommended that NobelParallel™ CC TiUltra™ implants are used only with dedicated Nobel Biocare surgical instruments and prosthetic components, as combining components that are not dimensioned for correct mating can lead to mechanical and/or instrumental failure, damage to tissue or unsatisfactory esthetic results.

It is strongly recommended that clinicians, new as well as experienced users of implants, prosthetics and associated software, always go through special training before undertaking a new treatment method. Nobel Biocare offers a wide range of courses for various levels of knowledge and experience. For more information please visit www.nobelbiocare.com.

When using a new device/treatment method for the first time, working with a colleague who is experienced with the new device/treatment method may help avoid possible complications. Nobel Biocare has a global network of mentors available for this purpose.

Before surgery:

Careful clinical and radiological examination of the patient has to be performed prior to surgery to determine the psychological and physical status of the patient.

Special attention has to be given to patients who have local or systemic factors that could interfere with the healing process of either bone or soft tissue or the osseointegration process (e.g., cigarette smoking, poor oral hygiene, uncontrolled diabetes, oro-facial radiotherapy, steroid therapy, infections in the neighboring bone). Special caution is advised in patients who receive bisphosphonate therapy.

In general, implant placement and prosthetic design must accommodate individual patient conditions. In case of bruxism or unfavorable jaw relationships reappraisal of the treatment option may be considered.

With respect to pediatric patients, routine treatment is not recommended until the end of the jaw bone growth phase has been properly documented.

Pre-operative hard tissue or soft tissue deficits may yield a compromised esthetic result or unfavorable implant angulations.

All components, instruments and tooling used during procedure must be maintained in good condition and care must be taken that instrumentation does not damage implants or other components.

At surgery:

Particular caution should be used when placing narrow platform implants in the posterior region due to risk of prosthetic overload.

Care and maintenance of instruments are crucial for a successful treatment. Sterilized instruments not only safeguard your patients and staff against infection but are also essential for the outcome of the total treatment.

Because of the small sizes of the devices, care must be taken that they are not swallowed or aspirated by the patient.

The implants may be tilted up to 45° relative to the occlusal plane. When used with angulations between 30° and 45°, the following applies: The tilted implant must be splinted; a minimum of 4 implants must be used when supporting a fixed prosthesis in a fully edentulous arch.

After the implant installation, the surgeon's evaluation of bone quality and primary stability will determine when implants may be loaded. Lack of adequate quantity and/or quality of remaining bone, infection and generalized diseases may be potential causes for failure of osseointegration both immediately after surgery, or after osseointegration is initially achieved.

Bending moments: Forces that cause bending moments are known to be the most unfavorable, as they can potentially jeopardize the long-term stability of an implant-supported restoration. In order to decrease bending moments, the distribution of forces should be optimized by cross-arch stabilization, minimizing distal cantilevers, having a balanced occlusion as well as decreased cuspal inclination of the prosthetic teeth.

If modifying the restoration, use copious irrigation and appropriate protection equipment. Avoid inhalation of dust.

After surgery:

To secure the long term treatment outcome, it is advised to provide comprehensive regular patient follow up after implant treatment and to inform about appropriate oral hygiene.

Surgical procedure:

1. During drilling procedures bone quality should be considered (please see table A: recommended drill sequences are based on bone quality to ensure optimal primary stability when applying immediate function).

A NobelParallel™ CC TiUltra™

Recommended drill sequence based on bone quality. Drill data are stated in mm and the drills within square brackets denote as optional.

Drill sequence according to bone quality:

Platform	Implant diameter	Soft Bone Type IV	Medium Bone Type II-III	Dense Bone Type I
NP	Ø 3.75	2.0 [2.4/2.8]	2.0 2.4/2.8 Cortical Drill 3.75 [Screw Tap 3.75]	2.0 2.4/2.8 2.8/3.2 Cortical Drill 3.75 Screw Tap 3.75
		2.0 2.4/2.8 [3.2/3.6]	2.0 2.4/2.8 3.2/3.6 Cortical Drill 4.3 [Screw Tap 4.3]	2.0 2.4/2.8 3.2/3.6 Cortical Drill 4.3 Screw Tap 4.3
RP	Ø 5.0	2.0 2.4/2.8 3.2/3.6 [3.8/4.2]	2.0 2.4/2.8 3.2/3.6 3.8/4.2 Cortical Drill 5.0 [Screw Tap 5.0]	2.0 2.4/2.8 3.2/3.6 3.8/4.2 Cortical Drill 5.0 Screw Tap 5.0
		2.0 2.4/2.8 3.2/3.6 4.2/4.6 [4.2/5.0]	2.0 2.4/2.8 3.2/3.6 4.2/5.0 Cortical Drill 5.5 [Screw Tap 5.5]	2.0 2.4/2.8 3.2/3.6 4.2/5.0 Cortical Drill 5.5 Screw Tap 5.5
WP	Ø 5.5	2.0 2.4/2.8 3.2/3.6 4.2/4.6 [4.2/5.0]	2.0 2.4/2.8 3.2/3.6 4.2/5.0 Cortical Drill 5.5 [Screw Tap 5.5]	2.0 2.4/2.8 3.2/3.6 4.2/5.0 Cortical Drill 5.5 Screw Tap 5.5

Note: all data is stated in mm.

Drilling must proceed at high speed (max. 2'000 rpm for Twist Drills and Twist Step Drills) under constant and profuse irrigation by sterile saline at room temperature. In dense bone situation drill with continuous back and forth motion.

Depth measurement system: The parallel drills have a true depth measurement system. All drills and components are marked to prepare the site to the correct depth and obtain a secure and predictable position.

Caution: Twist Drills and Twist Step Drills extend up to 1mm longer than the implant when seated. Allow for this additional length when drilling near vital anatomical structures (please see image B for drill reference lines).

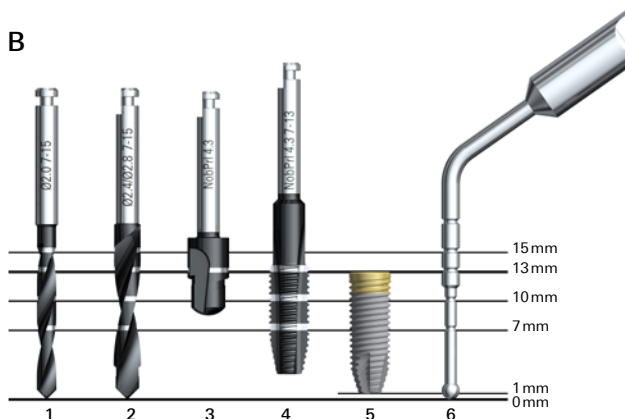

Note: The marks on the Twist Drills and Twist Step Drills indicate actual millimeter lengths and correspond to the implant collar. Final vertical positioning depends on several clinical parameters, including esthetics, tissue thickness and available vertical space.

In situations where adjacent natural teeth interfere with the contra-angle head preventing the drill from reaching the desired depth, a drill extension shaft may be used.

2. Prepare implant site. When using a flapless approach add-on soft tissue height to drill depth.
3. Measure the final depth of implant site for applicable implant length using depth probe with same measurements as Twist Drills and Twist Step Drills.
4. Open the implant package and pick up the implant from inner casing with implant driver (please see C). The implants are ideally installed with low speed, max. 25 rpm, using a drilling device.

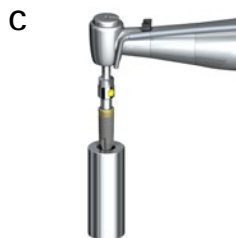

Pick up of implant from inner casing with implant driver

5. Place and tighten the implant using max. **45 Ncm** insertion torque.

Caution: Never exceed insertion torque of **45 Ncm** for the implants. Overtightening an implant may lead to damage of the implant, fracture or necrosis of the bone site. If a Surgical Driver is used to insert the implant, special care needs to be taken to avoid over tightening.

If the implant gets stuck during implant installation or **45 Ncm** of insertion torque is achieved before fully seated, rotate the implant counter clockwise using drilling device (reverse mode) or manual torque wrench and remove implant from site. Replace the implant back into inner casing before proceeding further.

6. Medium and dense bone protocol:
 - a. In cases of a thick cortical layer or dense bone a Cortical Drill and/or a Screw Tap is mandatory to be able to get the implant fully seated and to release pressure around the implant neck.
 - b. Select the Cortical Drill and/or use Screw Tap matching the diameter of the implant:
 - If Cortical Drill is used: proceed with drilling at high speed max. 2'000 rpm and drill to appropriate depth (see image B).
 - If Screw Tap is used: place the screw tap into prepared implant site using low speed 25 rpm and drill to appropriate depth (see image B). Switch the drill device with handpiece to reverse mode and remove the Screw Tap.
 - c. Continue with implant installation until desired position is achieved using max. **45 Ncm** of insertion torque.
7. For Immediate Function, the implant should be able to withstand a final torque between **35–45 Ncm**.
8. Depending on surgical protocol of choice, place a cover screw or an abutment and suture. See table D for implant specifications.

D

Implant specifications

Platform	Platform diameter	Implant diameter	Lengths
NP	Ø 3.5	Ø 3.75	7, 8.5, 10, 11.5, 13, 15, 18
RP	Ø 3.9	Ø 4.3 Ø 5.0	7, 8.5, 10, 11.5, 13, 15, 18 7, 8.5, 10, 11.5, 13, 15, 18
WP	Ø 5.1	Ø 5.5	7, 8.5, 10, 11.5, 13, 15

Note: all data is stated in mm.

Caution: Please note the NobelParallel™ CC TiUltra™ implant platform color is yellow for all implant sizes and does not reflect Nobel Biocare's platform color-coding.

For additional information on surgical procedures please consult the NobelParallel™ CC TiUltra™ "Procedures & products" treatment guidelines available at www.nobelbiocare.com or request latest printed version from a Nobel Biocare representative.

Materials:

NobelParallel™ CC TiUltra™ implant: commercially pure titanium grade 4, sodium dihydrogen phosphate (NaH₂PO₄) and magnesium chloride (MgCl₂).

Sterility and reusability information:

NobelParallel™ CC TiUltra™ Implants are delivered sterile for single use only. Do not use after the labeled expiration date.

Warning: Do not use device if the packaging has been damaged or previously opened.

Caution: NobelParallel™ CC TiUltra™ implants are single use products and must not be reprocessed. Reprocessing could cause loss of mechanical, chemical and / or biological characteristics. Re-use could cause cross contamination.

Magnetic resonance (MR) safety information:

The NobelParallel™ CC TiUltra™ implants have not been evaluated for safety and compatibility in the MR environment. They have not been tested for heating, migration, or image artifact in the MR environment. The safety of NobelParallel™ CC TiUltra™ implants in the MR environment is unknown. Scanning a patient who has this device may result in patient injury.

Storage, handling and transportation:

The device must be stored and transported in dry conditions in the original packaging at room temperature and not exposed to direct sunlight. Incorrect storage and transportation may influence device characteristics leading to failure.

Disposal:

Safely discard potentially contaminated or no longer usable medical devices as healthcare (clinical) waste in accordance with local healthcare guidelines, country and government legislation or policy.

Separation, re-cycling or disposal of packaging material shall follow local country and government legislation on packaging and packaging waste, where applicable.

Manufacturer and Distributor:

Manufacturer: Nobel Biocare AB, Box 5190, 402 26 Västra Hamngatan 1, 411 17 Göteborg, Sweden.
Phone: +46 31 81 88 00. Fax: +46 31 16 31 52. www.nobelbiocare.com



Distributed in USA by Nobel Biocare USA, LLC, Yorba Linda, CA, USA.

Distributed in Australia by:

Nobel Biocare Australia
Level 4/7 Eden Park Drive
Macquarie Park NSW 2114, Australia
Phone: +61 1800 804 597

Distributed in New Zealand by:

Nobel Biocare New Zealand
33 Spartan Road
Takanini, Auckland, 2105, New Zealand
Phone: +64 0800 441 657

Canada license exemption: Please note that not all products may have been licenced in accordance with Canadian law.

For Prescription Use Only.

Caution: Federal (United States) law restricts this device to sale by or on the order of a clinician, medical professional or physician.

Symbols Glossary:

The following symbols may be present on the device labeling or in information accompanying the device. Refer to the device labeling or accompanying information for the applicable symbols.



Authorized representative in the European Community



Batch code



Catalogue number



Caution



CE marking



Consult instructions for use



Contains hazardous substances



Contains or presence of phthalate



Date



Date of manufacture



Do not resterilize



Do not re-use



Do not use if package is damaged



Double sterile barrier system

Rx Only

For prescription use only



Health care centre or doctor



Keep away from sunlight



Keep dry

symbol.glossary.nobelbiocare.com
ifu.nobelbiocare.com

Link to Online Symbols Glossary and IFU Portal



Magnetic resonance conditional



Manufacturer



Medical device



Non-pyrogenic



Non-sterile



Patient identification



Patient information website



Patient number



Serial number



Single sterile barrier system



Single sterile barrier system with protective packaging inside



Single sterile barrier system with protective packaging outside



Sterilized using ethylene oxide



Sterilized using irradiation



Temperature limit



Tooth number



Upper limit of temperature



Sterilized using steam or dry heat



Unique Device Identifier



Use-by date

EN All rights reserved.

Nobel Biocare, the Nobel Biocare logotype and all other trademarks used in this document are, if nothing else is stated or is evident from the context in a certain case, trademarks of Nobel Biocare. Product images in this folder are not necessarily to scale. All product images are for illustration purposes only and may not be an exact representation of the product.